

Mission Success  
Ensign-Bickford Aerospace & Defense Company (EBAD) is dedicated to supporting our customers in the aerospace and defense industry through on-time delivery of innovative products that exceed expectations and assure mission success.

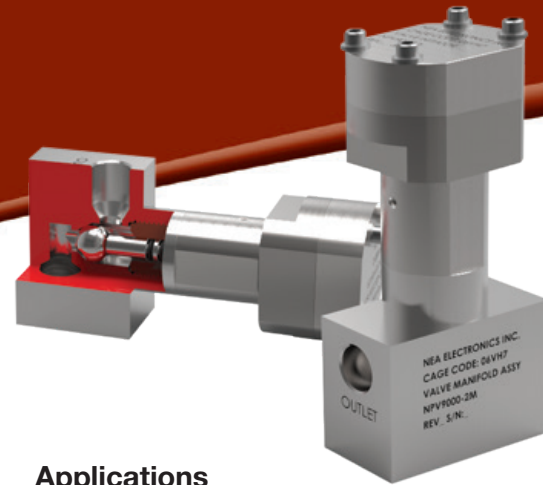

### Model NPV9000 Non-Pyrotechnic Valve

EBAD's highly reliable Hold Down & Release Mechanisms technology has been adapted for use in Non-Pyrotechnic Valves. The electrically redundant valves offer low shock and positive isolation with both liquid and gas lines. They are available in both normally closed and normally open configurations.

### Principle of Operation

The NEA® Non-Pyrotechnic Valves consist of a spring-loaded plunger that is restrained using the same patented split-spool and bridge wire technology used in our Hold Down & Release Mechanisms. The spool subassembly includes two spool halves which are held together by a tight winding of a restraining wire that terminates in a bridge wire connecting two electrical terminals at the electrical interface to the device. The spool assembly, by virtue of the restraining wire winding, can prevent axial motion of the plunger. When sufficient electrical current is passed through the terminals and the bridge wire, the bridge wire heats up and breaks under the applied tension load. This allows the restraining wire to unwind, separating the spool halves and releasing the spring-preloaded plunger, which is directly connected to a ball and cone valve mechanism. Actuation can either separate the ball from the cone or engage the ball in the cone depending on the configuration selected.

The actuation method is simple and reliable and forms the basis of actuation for many of EBAD's other products including; Battery Cell Bypass Switches and Pin Pullers.

### Applications

The Non-Pyrotechnic Valves are most suited to one shot applications that are inaccessible and require maximum reliability such as:

- Spacecraft fuel lines
- Nuclear coolant valves
- Tamper proof hydraulic valves for security applications

### Key Features

- Electrically Redundant
- Low Shock
- Positive Isolation
- Available in normally closed or open configurations
- Hermetically-sealed designs are available
- Post actuation contamination: <15 items and <25 microns
- Predictable Actuation Times
- Material selections compatible with gas and liquid mediums

### Model NPV9000 Technical Specifications

Parameter	Capability
Burst Pressure (5 minutes)	63.4 MPa (9,200 psi)
Maximum Operational Pressure	31 MPa (4,500 psi)
Minimum Operational Pressure	0 MPa (0 psi)
Minimum Actuation Current <sup>1</sup>	2 A
Actuation Time <sup>2</sup>	30 ms
Cold Temperature Limit	-257°C (16 K)
Hot Temperature Limit	+160°C
Mass <sup>3</sup>	496.5 g

Notes:

<sup>1</sup> Actuation can be achieved using a range of current, the value in the table is the value used for qualifying this device.

<sup>2</sup> Actuation time is dependent on actuation current, contact applications engineering for more specific information on actuation time as a function of current.

<sup>3</sup> Mass does not include harnessing and lead wires.

### Model NPV9000 Non-Pyrotechnic Valve Mechanical Interface Drawing

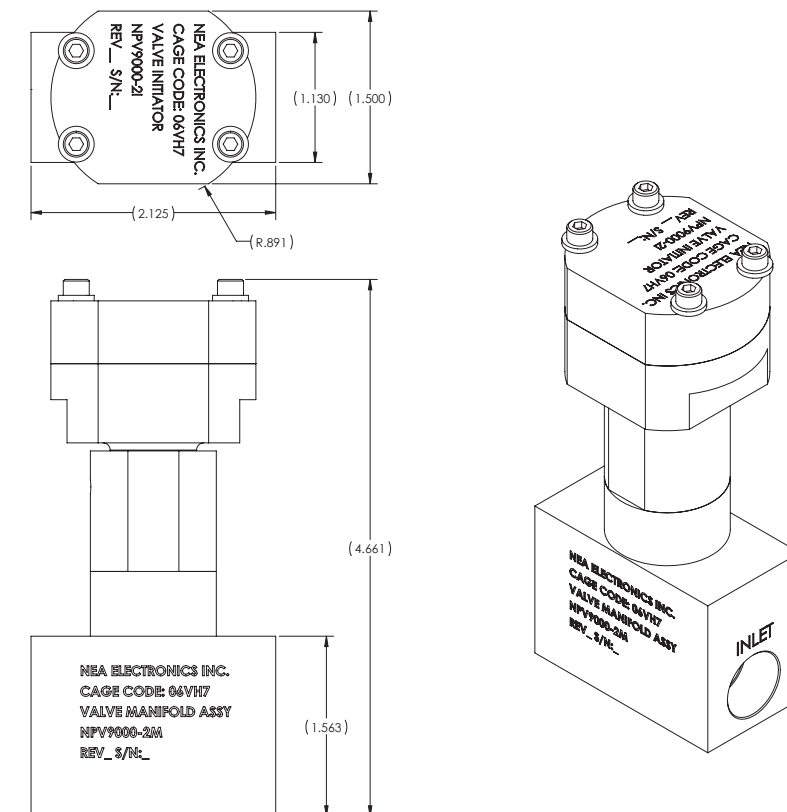

ENSIGN-BICKFORD AEROSPACE & DEFENSE COMPANY  
640 HOPMEADOW STREET, P.O. BOX 429, SIMSBURY, CT 06070, USA [www.EBAD.com](http://www.EBAD.com)

NEA® is a registered trademark of NEA Electronics, Inc. This product and its components are protected under U.S. Patent Numbers 6,433,990 / 6,249,063 as well as France Patent Numbers 125567 / 9903335, U.K. Patent Number 1255675 and Germany Patent Number 60111923.1.

**Attention:** The information and recommendations described in this brochure cannot possibly cover every application of the products or variation of conditions under which the products are used. The recommendations here in are based on the manufacturer's experience, research and testing. They are believed to be accurate, but no warranties are made, express or implied. In addition, the specifications contained herein are all nominal which represent our current production. The products described may be subject to change. Please feel free to contact Ensign-Bickford Aerospace & Defense Company for verification. No Warranties or Liabilities: THE PRODUCTS DESCRIBED HEREIN are sold "AS IS" and without any warranty or guaranty, express, or implied, arising by law or otherwise including without limitation any warranty of merchantability or fitness for a particular purpose. Buyer and user agree further to release and discharge seller from any and all liabilities whatsoever arising out of the purchase or use of any product described herein whether or not such liability is occasioned by seller's negligence or based upon strict products liability or upon principles of indemnity or contribution. Content©2021 Ensign-Bickford Aerospace & Defense Company, Simsbury, CT 06070, U.S.A.